

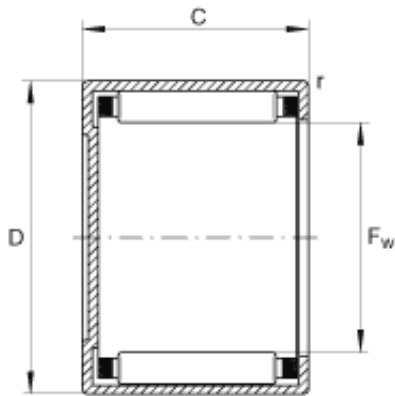

Korean motorcyclist Co., Ltd



INA BCE88 Drawn Cup Needle Roller Bearings

Bearing No. BCE88

Size	12.7x17.462x12.7 mm
Bore Diameter	12,7 mm
Outer Diameter	17,462 mm
Width	12,7 mm
F_w	1/2 inch
F_w	12,7 mm
D	0,687 inch
D	17,462 mm
C	0,5 inch
C	12,7 mm
m	0,016 lbs / Weight
m	7 g / Weight
C_r	1550 lbf / Dynamic load rating (radial)
C_r	6900 N / Dynamic load rating (radial)
C_{Or}	2030 lbf / Static load rating (radial)
C_{Or}	9000 N / Static load rating (radial)
n_G	19500 1/min / Limiting speed
n_B	13500 1/min / Reference speed
Category	Needle Non Thrust Roller Bearings
Inventory	1.0
Manufacturer Name	SCHAEFFLER GROUP

BCE88 Bearing 2D drawings and 3D CAD models



Korean motorcyclist Co., Ltd

Minimum Buy Quantity	N/A
Weight / Kilogram	0.009
Product Group	B04144
Rolling Element	Needle Roller Bearing
Component	Roller Assembly with Outer Ring - No Inner Ring
Enclosure	Open
Self Aligning	No
Retainer	Yes
Number of Rows of Rollers	Single Row
Separable	No
Closed End	Yes
Inch - Metric	Inch
Relubricatable	No
Thrust Bearing	No
Long Description	1/2" Bore; 11/16" Outside Diameter; 1/2" Width; Needle Roller Bearing; Roller Assembly with Outer Ring - No Inner Ring; Open Enclosure; No Self Aligning; Yes Retainer; Single Row of Rol
Other Features	1 Rib Outer Ring Drawn Cup Bearing Steel Cage
Category	Needle Non Thrust Roller Bearing
UNSPSC	31171512
Harmonized Tariff Code	8482.40.00.00
Noun	Bearing
Keyword String	Needle
Manufacturer URL	http://www.ina.com
Manufacturer Item Number	BCE88
Weight / LBS	0.016
Width	0.5 Inch 12.7 Millimeter



Korean motorcyclist Co., Ltd

Outside Diameter	0.688 Inch 17.475 Millimeter
Bore	0.5 Inch 12.7 Millimeter